

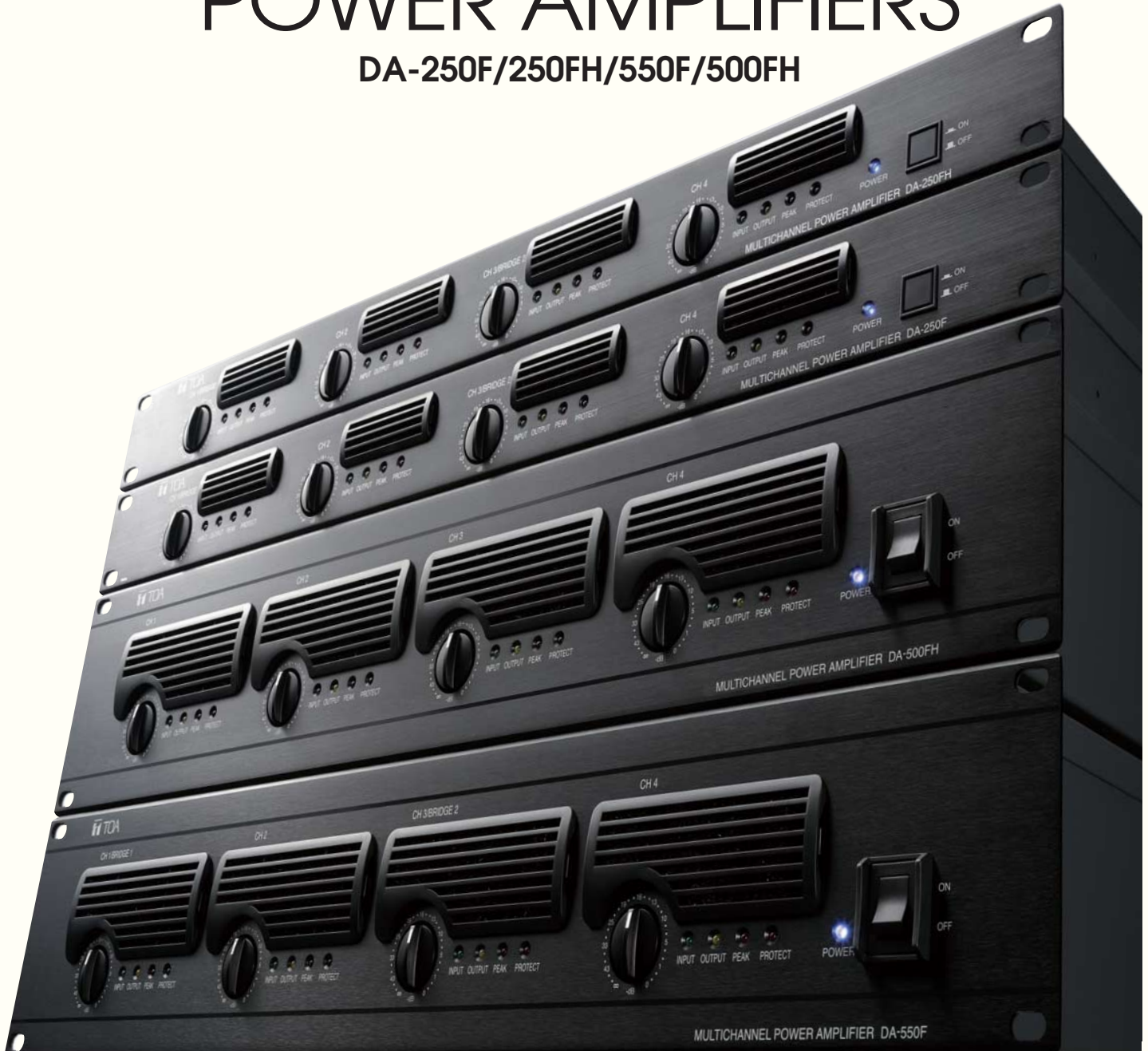

4-CHANNEL DIGITAL POWER AMPLIFIERS

DA-250F/250FH/550F/500FH



***Top-of-the-line operation and
performance efficiency***

Full Digital Amplifier*

*Amplifiers feature switching power supply and Class-D technology.



TOA Digital Amplifier Technology Redefines the Very Concept of Amplifiers.

The power supply unit is the heart of the amplifier. To ensure consistently high performance and reliable operation, TOA engineers have given the DA Series a system that provides power independently to each of the four channels.

This testifies to TOA's attitude to product development, which is always totally motivated by the desire to provide high-quality products that offer worry-free use.

Never compromise —
that's the TOA philosophy.

FEATURES

Highly efficiency

Extremely high amplification efficiency of 80-90%, resulting in reduction in power consumption by more than 60% compared with Class-AB amplifiers.

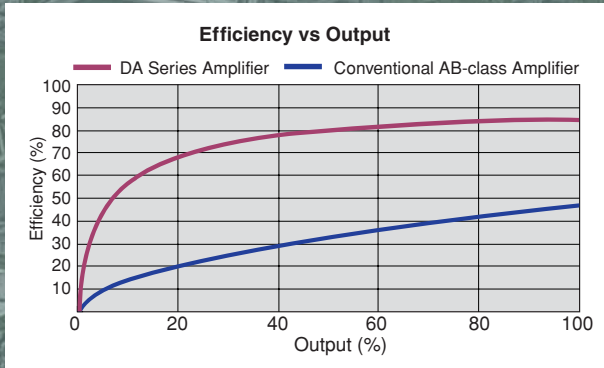

Amplifier with world-class lightweight design*

Installation has become much easier thanks to the lightweight design.

*TOA comparative data (weight/watt)

Compact design

The DA-250 Series is 1-unit size and the DA-500 Series is 2-unit size, and they can be efficiently mounted on a rack, so they require only a small installation space. Because the amplifiers do not generate much heat, 5 units can be stacked together in a rack.

Highly durable

Stands up to extended hours of operation. TOA has been conducting a "non-stop driving test" of the DA-250 Series.

High reliability

The DA amplifier has a comprehensive protection circuitry, and has undergone a large number of rigorous tests to prove its durability.

Independent power supply

Each of the channels has its own power supply. If the power supply of Channel 1 should fail, this won't affect the operation of Channels 2-4. It is also possible to use one of the channels as a spare amplifier.

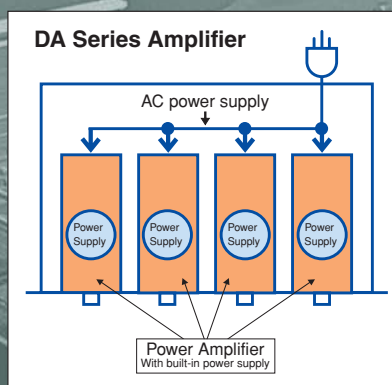
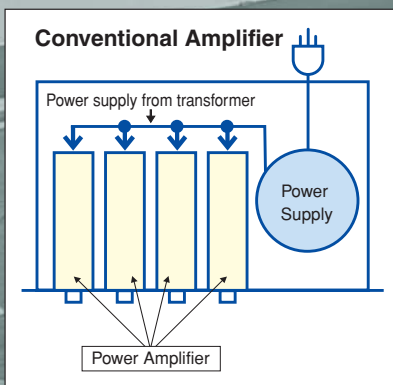
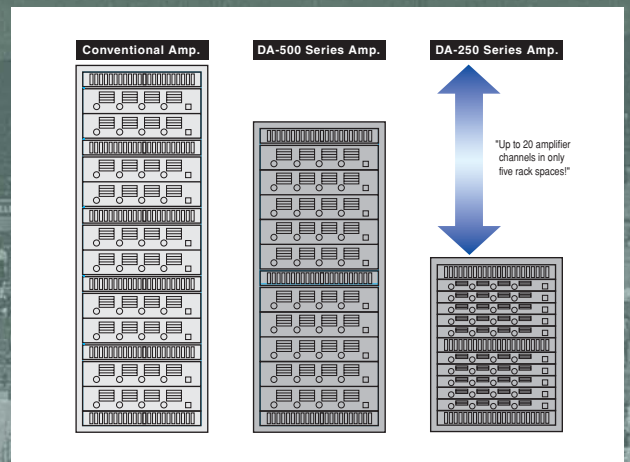



Design Optimization for Efficient and Reliable High-level Performance

The TOA DA-250F/FH and DA-550F/500FH multi-channel power amplifiers offer a wider choice of power ratings, advanced digital Class D amplification circuitry, and a highly efficient AC mains to output power ratio, for the complete technological superiority it takes to support long-term installation applications. These

energy-efficient, space-saving amplifiers are designed to combine high levels of performance and efficiency, and are well-suited to ensure sound reinforcement reliability in a wide range of venue types.

The "F" models are ideal for multi-zone applications such as presentation and press-conference rooms, restaurants and similar-sized locations. The "FH" units are well-suited to such locations as exhibition halls, sports facilities, multipurpose halls and houses of worship.

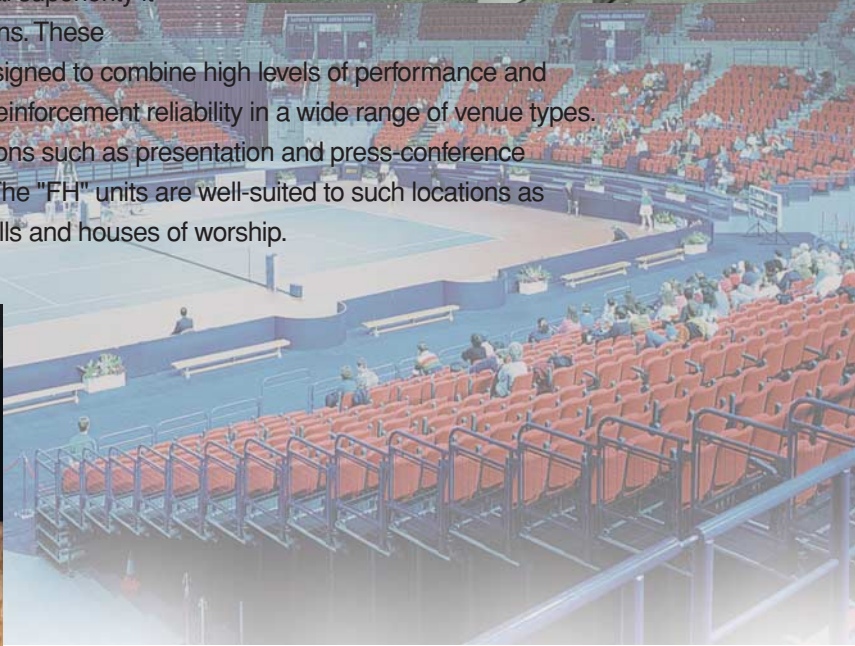



DA-250F (rear)



DA-500FH (rear)

MT-250H
Matching Transformer



- Capacity:** 0 – 250W
- Primary impedance:** 100V line : 40Ω/66.6Ω/70V line : 19.6Ω/32.6Ω
- Secondary impedance:** 100V line : 40Ω/66.6Ω/70V line : 19.6Ω/32.6Ω/50V line : 10Ω/16.6Ω
- Frequency response:** 30Hz – 18kHz (+0dB, -3dB)
- Connection terminal:** M4 screw terminal, distance between barriers: 8.1mm
- Weight:** 3.7kg

SPECIFICATIONS

Model	DA-250F	DA-250FH	DA-550F	DA-500FH
Power Req.	220 – 240V AC, 50/60Hz			
Number of Channels	4			
Total Output All Channel Driven	1000W (1kHz, 4Ω) 680W (1kHz, 8Ω)	1000W (1kHz, 40Ω)	2200W (1kHz, 4Ω) 1400W (1kHz, 8Ω)	2000W (1kHz, 20Ω)
Output Voltage per Channel	31.6V (1kHz, 4Ω) 36.9V (1kHz, 8Ω)	100V (1kHz, 40Ω)	46.9V (1kHz, 4Ω) 52.9V (1kHz, 8Ω)	100V (1kHz, 20Ω)
Output Current per Channel	7.9A (1kHz, 4Ω) 4.6A (1kHz, 8Ω)	2.5A (1kHz, 40Ω)	11.7A (1kHz, 4Ω) 6.6A (1kHz, 8Ω)	5A (1kHz, 20Ω)
Power Output				
8 ohms per channel	170W	—	350W	—
4 ohms per channel	250W	—	550W	—
16 ohms bridged	340W	—	700W	—
8 ohms bridged	500W	—	1100W	—
Hi-Z: 70V/100V per channel	—	250W	—	500W
Power Consumption*				
Rated power consumption (1kHz)				
8 ohms	800W, 5.8A	—	1550W, 11.3A	—
4 ohms	1200W, 8.7A	—	2750W, 19.9A	—
70 Volts	—	—	—	—
100 Volts	—	1150W, 8.3A	—	2300W, 16.8A
Idle power consumption	48W, 0.3A	75W, 0.5A	57W, 0.4A	65W, 0.5A
1/8 Power 8 ohms (Pink noise)	167W, 1.2A	—	325W, 2.2A	—
4 ohms	248W, 1.6A	—	442W, 2.7A	—
70 Volts	—	—	—	—
100 Volts	—	270W, 1.9A	—	493W, 3.1A
1/3 Power 8 ohms (Pink noise)	349W, 2.4A	—	733W, 5.1A	—
4 ohms	511W, 3.7A	—	1119W, 8.0A	—
70 Volts	—	—	—	—
100 Volts	—	491W, 3.5A	—	1026W, 7.4A
1/8 Power 8 ohms (1kHz)	143W, 1.0A	—	273W, 1.8A	—
4 ohms	202W, 1.4A	—	411W, 2.7A	—
70 Volts	—	—	—	—
100 Volts	—	230W, 1.6A	—	399W, 2.6A
1/3 Power 8 ohms (1kHz)	284W, 1.9A	—	632W, 4.4A	—
4 ohms	437W, 3.0A	—	958W, 6.9A	—
70 Volts	—	—	—	—
100 Volts	—	443W, 3.0A	—	860W, 6.1A
Frequency Response	20Hz – 20kHz (±1dB)	50Hz – 20kHz (–3dB, 0dB)	20Hz – 20kHz (–2dB, +1dB)	50Hz – 20kHz (–3dB, +1dB)
THD	0.1 % (1kHz) 0.3 % (20Hz – 20kHz)	0.1 % (1kHz) 0.3 % (100Hz – 20kHz)	0.1 % (1kHz) 0.15 % (20Hz – 20kHz)	0.1 % (1kHz) 0.3 % (100Hz – 20kHz)
S/N Ratio (A weighted)	100dB			
Crosstalk at 10kHz (A weighted)	70dB			
DC Offset*	±5mV			
Voltage Gain*	29.5dB	38.2dB	32.6dB	38.2dB
Damping Factor*	100 (1kHz, 8Ω)	300 (1kHz, 40Ω)	95 (1kHz, 8Ω)	240 (1kHz, 20Ω)
Inputs	10kΩ (unbalanced), 20kΩ (balanced) +4dB (1.23V) 14V (25.1dBu)		10kΩ (unbalanced), 20kΩ (balanced) +4dB (1.23V) 12V (23.8dBu)	
Protection Circuit	Amplifier section Power supply section	DC output, overheat protection, load shorting, overload current, maximum output Overheat protection, AC rush current		
Cooling	Continuously constant speed fan with front-to-rear airflow, 50,000 hours life time at 25°C		Continuously constant speed fan with front-to-rear airflow, 100,000 hours life time at 25°C	
Operating Temperature	–10°C to +40°C			
Operating Humidity	Under 90% RH (no condensation)			
Dimensions	482 (W) × 44 (H) × 401 (D)mm		482 (W) × 88.4 (H) × 404.2 (D)mm	
Weight	6.8kg		9kg	
Finish	Panel: Aluminum, alumite process, black Case: Plated steel sheet			
Accessory	Euro style terminal block connector (3-pin) × 4, Tamper-proof cap × 4, Rack mounting screw × 4			
Option	—	Matching transformer: MT-250H	—	Matching transformer: MT-250H

0dB=0.775Vrms

*Typical data

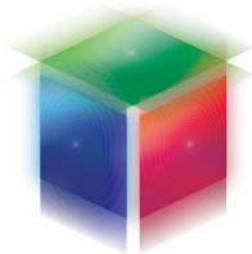

Human Society with
Sound & Communication

TOA Corporation
www.toa.jp

Specifications are subject to change without notice.
Printed in Japan (0709) 833-52-357-60 u