

REFLEX HORNS AND DRIVER UNITS

TH-650



TH-660



DESCRIPTION

TOA's TU Series Driver Units are designed to be used in combination with TOA's TH-650 or TH-660 round horn. The TH/TU combined speaker can be used for both indoor and outdoor applications, as well as for background music reproduction. The lineup includes four models rated at 30 W (TU-630 and TU-630M) and 50 W (TU-650 and TU-650M). The "M"-type models are designed for use in high-impedance (70V/100V lines) systems and standard models for low-impedance (16 Ω) systems. This wide product lineup permits selection of the ideal speaker for most applications.

TU Series driver units feature newly developed diaphragms employing special heat-resistant fibers impregnated with phenolic resin to prevent the diaphragm from absorbing moisture and changing shape. High speaker efficiency has also been realized by minimizing the gap produced when the diaphragm bobbin is installed in the magnetic circuitry slit. The aluminum foil bobbin also features excellent heat dissipation properties to resist high power inputs and ensure high speaker durability.

High-impedance models are equipped with an input impedance selector switch which facilitates impedance settings without requiring disassembly. The switch is also equipped with an OFF position to prevent speaker damage resulting from incorrect impedance setting.

TH Series horns have two types of 500 mm and 600 mm in diameter. Both types feature TOA's round shape to ensure high speech clarity and sound quality suitable for music reproduction.

All external hardware (screws, bolts, nuts) are made of stainless steel, while the mounting bracket and the horn itself are treated with 50-micron thick powder paint coating which is about three times thicker than that of the conventional horns. All of these factors combine to ensure the speaker's excellent weatherproofing and corrosion resistance. In addition, the external horn flare is made of aluminum which is more shock-resistant than resin.

FEATURES

TU Series Driver Units

- Both high-impedance (70V/100V lines) models and low-impedance (16 Ω) models available.
- Two power ratings: 30 W and 50 W.
- Input impedance selector on high-impedance models facilitates input impedance matching from the outside.
- Gray color (corresponding to RAL 7042) helps driver units match off-white horns.
- Compliance with IP65.

TH Series Horns

- External stainless steel hardware (screws, bolts, nuts), and powder-coated horn and bracket ensure superb weatherproofing and corrosion-resistance.
- Shock-resistant aluminum round horn.
- Unobtrusive two-tone colors (off-white color corresponding to RAL 9010:horn, and gray corresponding to RAL7042: bracket) help speakers blend in with surroundings.



TU-630
TU-650



TU-630M
TU-650M

TU-630/TU-630M+TH-650

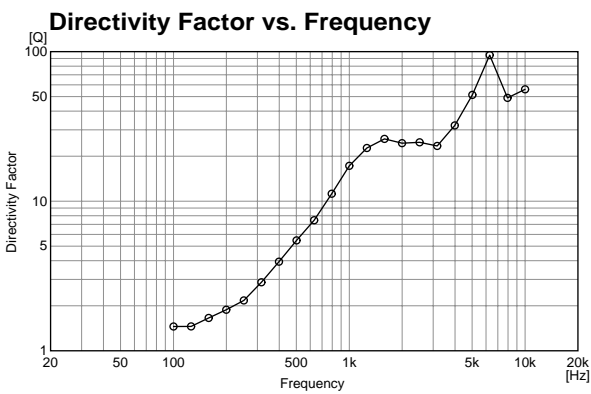
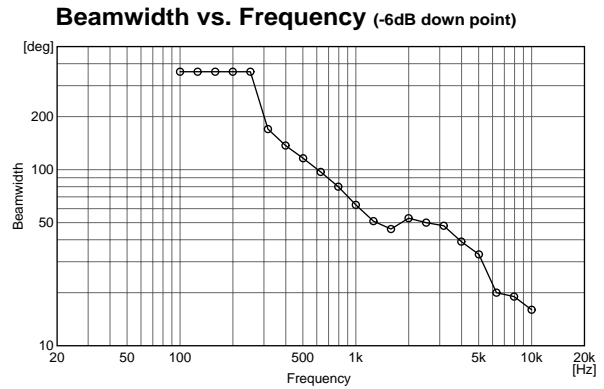
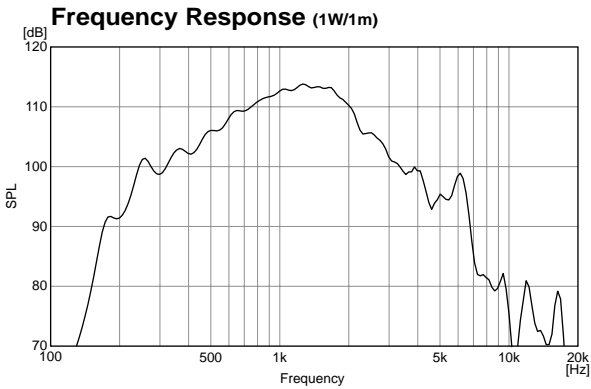

Polar Response

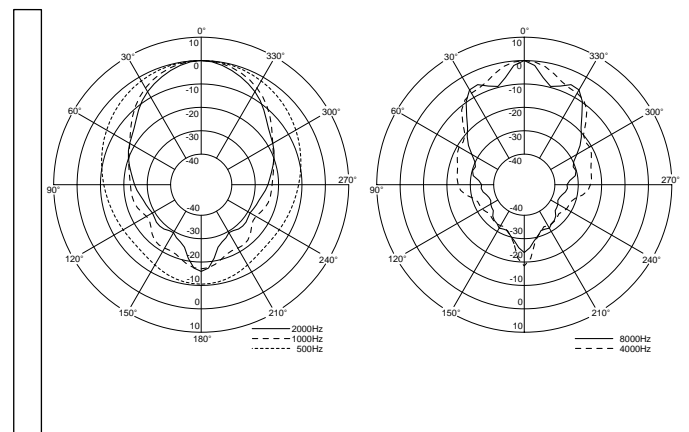

TU-650/TU-650M+TH-650

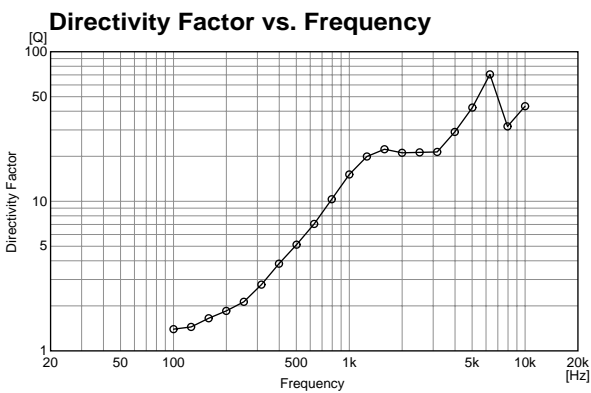
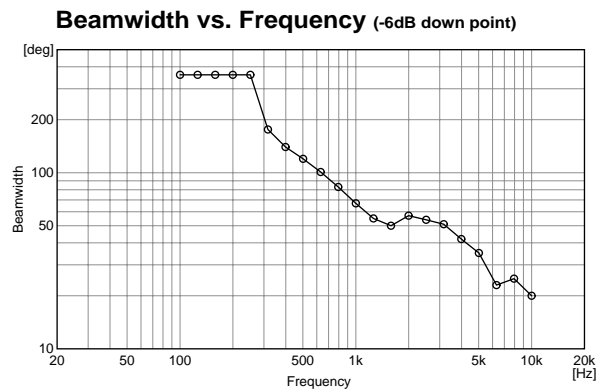
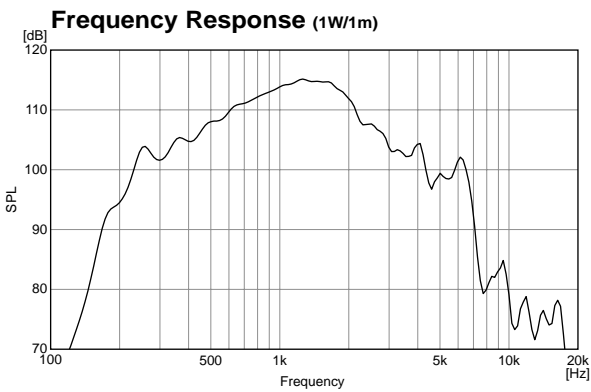

Polar Response

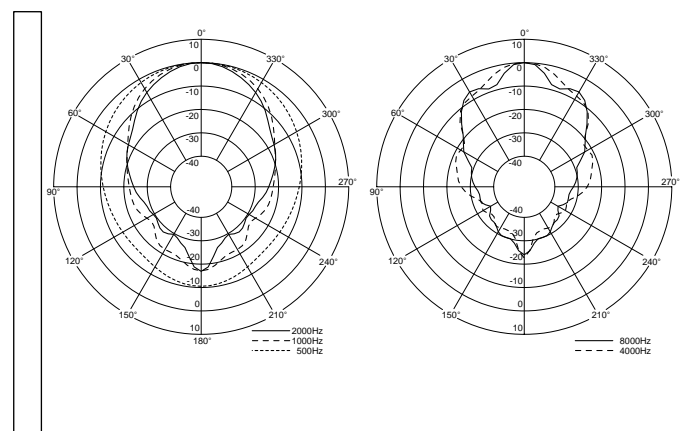

TU-630/TU-630M+TH-660

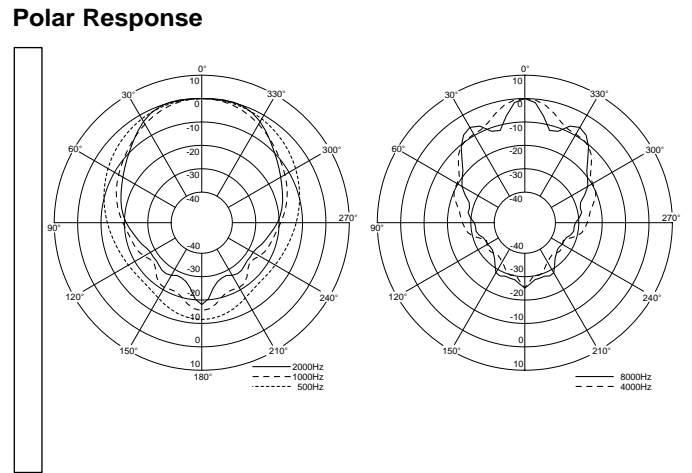
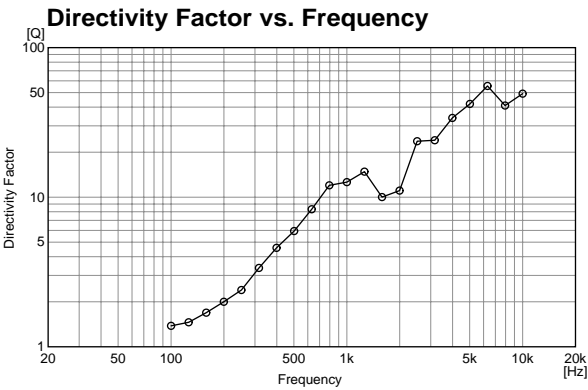
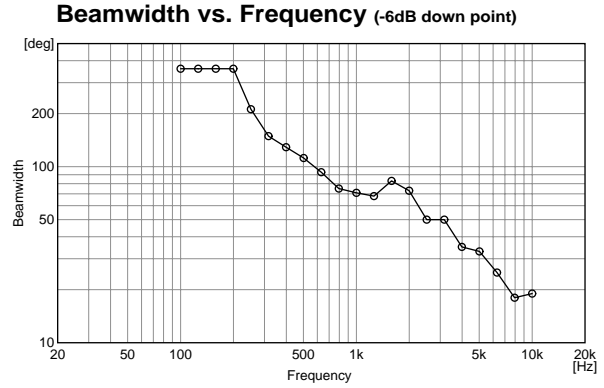
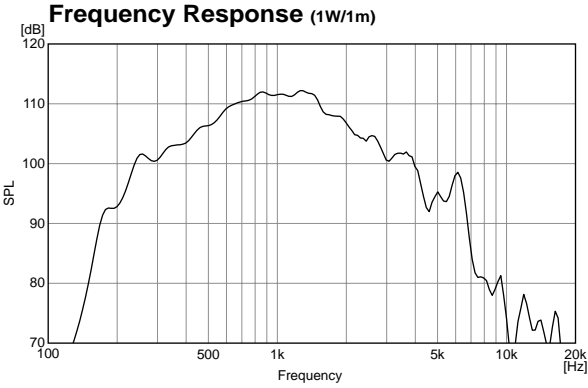

TU-650/TU-650M+TH-660

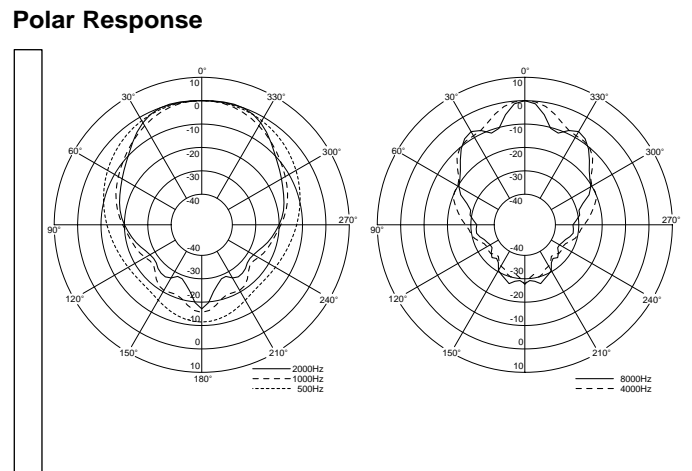
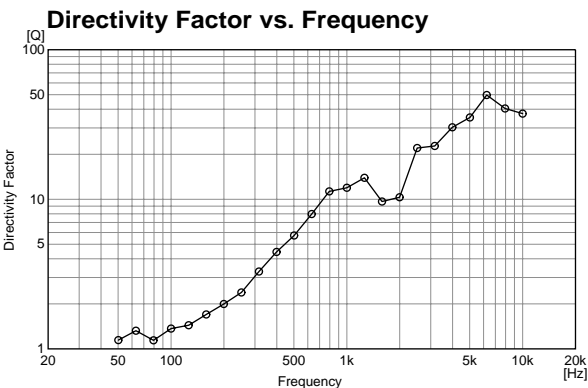
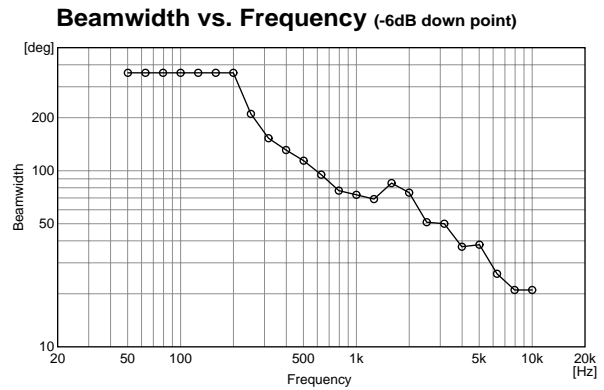
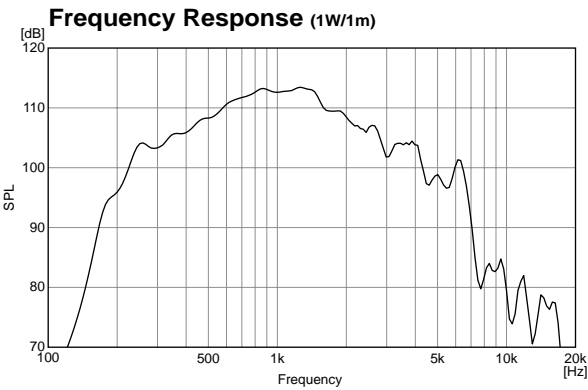

SPECIFICATIONS

	TH-650	TH-660
Sound Pressure Level	110 dB (1 W, 1 m) (When operated with a driver.)	
Frequency Response	200 – 6,000 Hz (When operated with a driver.)	
IP Code	IP 65 (When operated with a driver.)	
Driver Coupling	1 ³ / ₈ 18 threads (inch screw)	
Operating Temperature	-20°C to +55°C (must be free from dew condensation)	
Finish	Horn flare and flange: Aluminum, off-white, powder coating Reflector horn: ABS resin, off-white Bracket holder: Aluminum, gray, powder coating Bracket: Steel, gray, powder coating Screws and bolts: Stainless steel	
Dimensions	ø500 x 394 (D) mm	ø600 x 425 (D) mm
Weight	2.9 kg	3.6 kg

DRIVER UNIT COVER



	TU-630	TU-630M	TU-650	TU-650M
Read Input	30 W	30 W	50 W	50 W
Line Voltage	—	100 V line or 70 V line	—	100 V line or 70 V line
Rated Impedance	16 Ω	100 V line: 330 Ω (30 W), 670 Ω (15 W), 1 kΩ (10 W), 2 kΩ (5 W) 70 V line: 170 Ω (30 W), 330 Ω (15 W), 670 Ω (7.5 W), 1 kΩ (5 W), 2 kΩ (2.5 W)	16 Ω	100 V line: 200 Ω (50 W), 330 Ω (30 W), 670 Ω (15 W) 70 V line: 100 Ω (50 W), 200 Ω (25 W), 330 Ω (15 W), 670 Ω (7.5 W)
Sound Pressure Level	110 dB (1 W, 1 m) (When operated with JIS C 5504 standard horn.)			
Frequency Response	150 – 6,000 Hz (When operated with JIS C 5504 standard horn.)			
IP Code	IP 65 (When operated with a horn.)			
Horn Coupling	1 ³ / ₈ 18 threads (inch screw)			
Polarity	Hot: Black, Corn: White			
Operating Temperature	-20°C to +55°C (must be free from dew condensation)			
Finish	Flange: Aluminum, gray, powder coating Rear cover: ABS resin, gray Screws: Stainless steel Speaker cable: Polyvinyl chloride insulated cabtyre cable (6 mm in diameter, 600 mm in length)			
Dimensions	ø139 x 106 (D) mm	ø139 x 149 (D) mm	ø139 x 106 (D) mm	ø139 x 149 (D) mm
Weight	1.4 kg	1.9 kg	2.1 kg	2.7 kg
Option	Driver unit cover: UC-200A Matching Transformer: MT-30T, MT-60T	Driver unit cover: UC-200A	Driver unit cover: UC-200A Matching Transformer: MT-30T, MT-60T	Driver unit cover: UC-200A

APPEARANCE AND DIMENSIONAL DIAGRAMS

